



Cable recycling plants and machinery

The best of cable recycling



ELDAN CABLE RECYCLING PLANTS AND MACHINES

The standard setup includes a Rasper, a Granulator and a Separation Table – we have standard plants with capacities ranging from 300-4000 kgs/ production hour. This is also the starting point when plants are tailored to suit specific customer requirements.

Proven technology

Eldan equipment is designed to meet market requirements, thus the individual machines can easily be adjusted to various types of dry cables such as hair-wire, harness wire, communication wire, installation wire, power cables, aluminium wire, copper wire, mixed household wire.

We also have plants for processing of greasy underground cables and jelly filled cables.

FEATURES

- High performance
- Low processing costs
- Low power consumption
- Low maintenance costs
- Minimum loss of metals
- Minimum 99,5% metal purity
- Eldan plants/machines are based on ambient mechanical technique for size reduction and separation, no melting or chemical treatment is required.
- Eldan plants are tailored to suit your requirements and facilities.

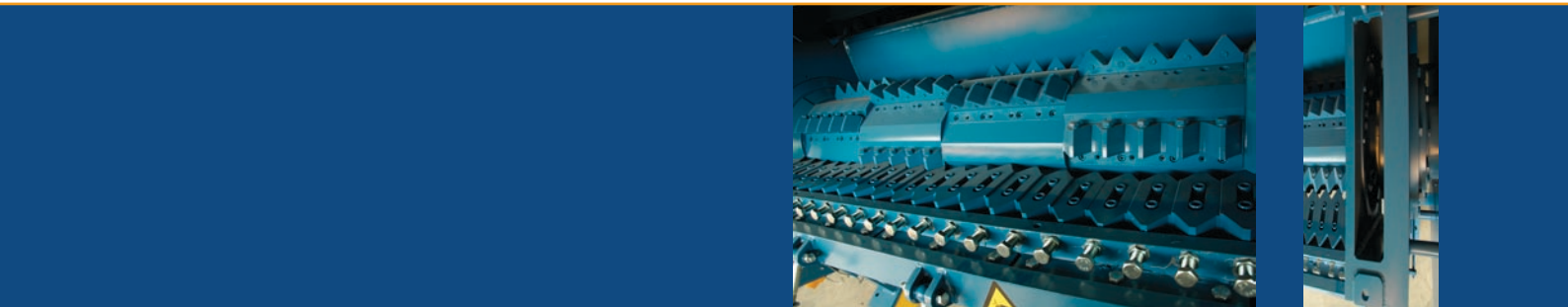

Input

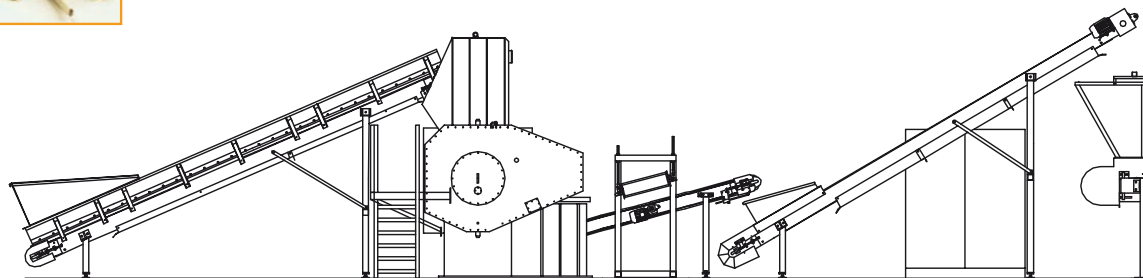

Multi Purpose Rasper

This machine is an effective, medium-speed, dual drive Rasper designed for cable recycling. It ensures individual size reduction down to approx. 15-25 mm fraction sizes.



Chopped material

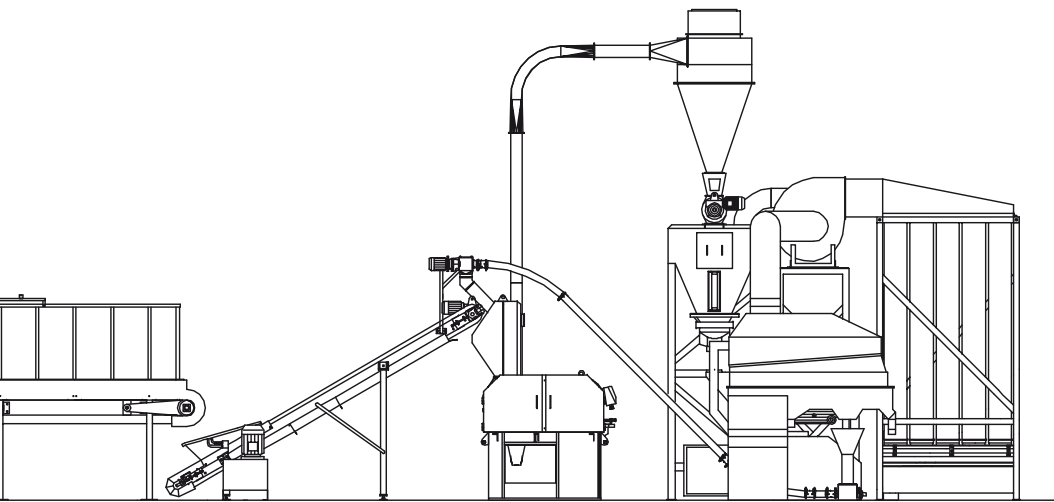

Fine-Granulator

A high-speed, single shaft Fine-Granulator for final granulation stage and opening of the cables. Fraction sizes typically between 4-7 mm granulate.

Separation Table

For the final separation of material into a 99,5% (or better) clean metal fraction.

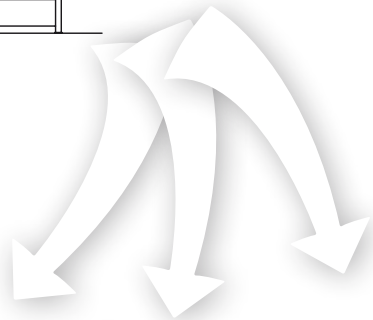

Organic/insulation granulate

Aluminium granulate

Copper granulate

REDUCE DOWNTIME

Eldan After-Sales-Division - your reliable partner!

We offer ad hoc service on existing as well as new equipment through our trained and experienced service engineers and supervisors.

Eldan constantly holds an extensive stock of parts.

Flexible Service Contracts with Eldan ASD ensures planned, preventive maintenance of your production line.

Tailored contracts ensure that parts are available for immediate call off.

By contacting one of our parts co-ordinators you will get the best possible solution for your company.



OPTIONAL MODULES FOR SPECIFIC CUSTOMER REQUIREMENTS

Super Chopper A powerful, low-speed, single or dual shaft pre-chopper used for pre-chopping of the input material – partly to size reduce the input and partly to increase the capacity of the cable recycling plant.

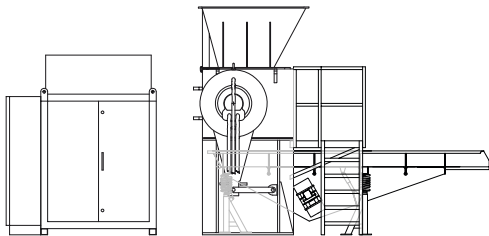

Classifier PC12 for recovery of the metals remaining in the plastic fraction. Reduction of the metal losses down to as little as 1%.

Water Separation Table for recovery of the metals remaining in the plastic fraction. Reduction of metal losses down to as little as 0,2%. Also enabling an increase of the capacity of the entire plant.

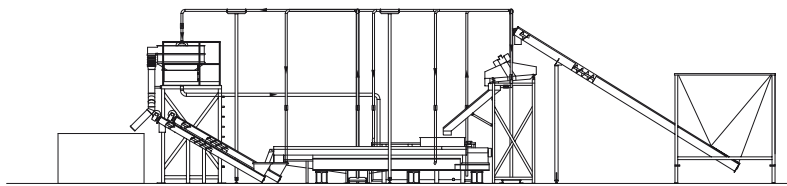

Cable Strippers for stripping of cables

- They are rugged
- They are reliable
- They are safe to operate
- They are simple to operate
- They are easy and inexpensive to maintain
- Cable diameters from 10-150 mm
- Capacity: 30 meters per minute

ELDAN - A name to remember



ELDAN RECYCLING A/S | Værkmestervej 4 | DK-5600 Faaborg | Denmark | Phone +45 63 61 25 45 | Fax +45 63 61 25 40 | www.eldan-recycling.com

Your local representative in Romania is Arcon Overseas Limited

Arcon